

1. DESCRIPTION

The BA377E-SS is an intrinsically safe, one input instrument in a rugged 316 stainless steel enclosure that can be configured as a Timer or as a Clock. As a Timer the BA377E-SS is able to measure and display the elapsed time between external events, or control external events via two optional factory fitted control outputs. When configured as a Clock the BA377E-SS displays local time and the optional control outputs can turn *on* and *off* twice in each twenty four hour period.

This abbreviated instruction sheet is intended to assist with installation, a comprehensive instruction manual describing safety certification, system design and configuration may be downloaded from the BEKA website or may be requested from the BEKA sales office.

The BA377E-SS has IECEx, ATEX and UKEX intrinsic safety certification for use in flammable gas and dust atmospheres. ETL and cETL approval permits installation in the USA and Canada. The certification information label, which is located on the top of the instrument enclosure, shows the certification numbers and codes. Other certifications may be shown. Copies of certificates may be downloaded from the BEKA website.



Typical certification information label

Special conditions for safe use

The IECEx, ATEX and UKEX intrinsic safety certificate numbers have an 'X' suffix indicating that for some applications special conditions apply for safe use.

- When installed in an Ex e, Ex p or Ex t panel enclosure all connections to the BA377E-SS must be made by appropriately rated Zener barriers or galvanic isolators.

This means that when installed in an Ex e, Ex p or Ex t panel enclosure the BA377E-SS remains an intrinsically safe instrument.

- The front of the stainless steel enclosure complies with the requirements for Ex e, Ex p & Ex t type of protection.

Therefore when correctly installed the BA377E-SS Timer or Clock will not invalidate the Ex e, Ex p or Ex t panel enclosure certification.

Use in combustible dust atmospheres

See full instruction manual for installation information requirements and special conditions for safe use in combustible dust atmospheres.

2. INSTALLATION

Although the BA377E-SS has IP66 front of panel protection it should be shielded from continuous direct sunlight and severe weather conditions. The rear of the instrument has IP20 protection.

Cut-out dimensions

Mandatory to achieve an IP66 seal between instrument and panel and to maintain certification of panel enclosure in which it is mounted.

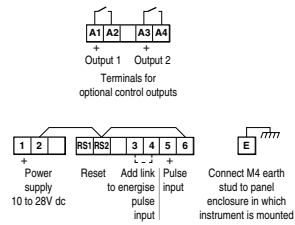
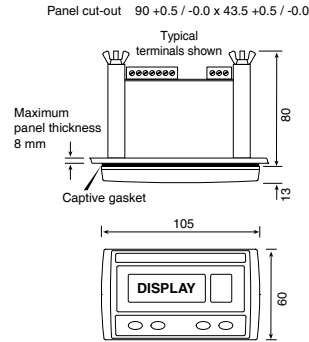

Support panel wiring to prevent vibration damage

Fig 1 Cut-out dimensions and terminals

**Abbreviated instructions for
BA377E-SS Rugged one input
intrinsically safe Timer or Clock**

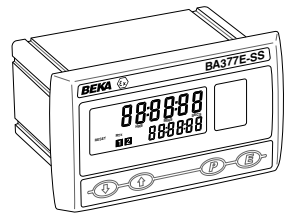

Issue 5
24th November 2022

BEKA associates Ltd. Old Charlton Rd, Hitchin, Hertfordshire, SG5 2DA, UK Tel: +44(0)1462 438301 e-mail: sales@beka.co.uk web: www.beka.co.uk

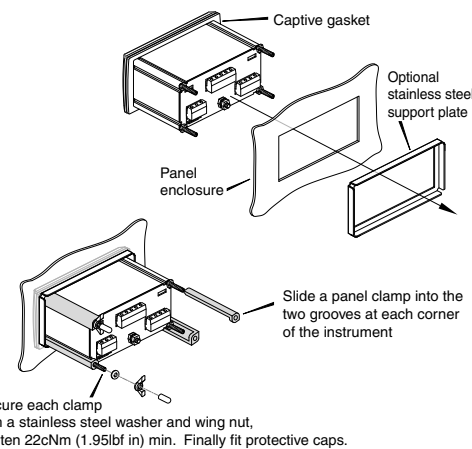

Secure each clamp with a stainless steel washer and wing nut, tighten 22cNm (1.95lbf in) min. Finally fit protective caps.

Fig 2 Installation procedure

EMC

For specified immunity all wiring should be in screened twisted pairs with screens earthed at one point within the safe area.

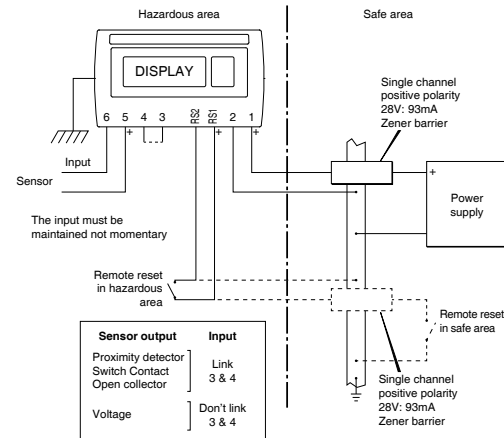

Fig 3 Use with Zener barriers

Scale card

The Timer or Clocks units of measurement are shown on a printed scale card visible through a window at the right hand side of the display. The scale card is mounted on a flexible strip that is inserted into a slot at the rear of the instrument as shown below

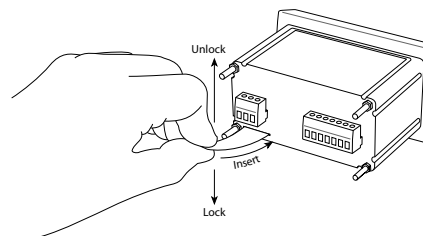

Fig 4 Inserting flexible strip carrying scale card into slot at the rear of Timer or Clock.

Thus the scale card can easily be changed without removing the Timer or Clock from the panel or opening the instrument enclosure.

New Timer or Clocks are supplied with a printed scale card showing the requested units of measurement, if this information is not supplied when the Timer or Clock is ordered a blank card will be fitted.

A pack of self-adhesive scale cards printed with common units of measurement is available as an accessory from BEKA associates. Custom printed scale cards can also be supplied.

To change a scale card, unclip the protruding end of the flexible strip by gently pushing it upwards and pulling it out of the enclosure. Peel the existing scale card from the flexible strip and replace it with a new printed card, which should be aligned as shown below. Do not fit a new scale card on top of an existing card.

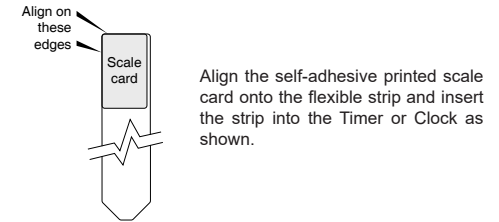

Fig 5 Fitting scale card to flexible strip

3. OPERATION

The Timer or Clock is controlled by four front panel push buttons. When in the Timer operating mode they have the following functions:

- [P] + [E]** Access to configuration menu.
- [▼]** When local control is enabled starts the Timer
- [▲]** When local control is enabled stops the Timer.
- [E] + [▲]** Shows the grand total (run time) in hours and tenths of an hour irrespective of Timer configuration. If buttons are held for longer than ten seconds the grand total may be reset to zero if the grand total reset sub-function [Lr] [Gt] is enabled in the [Lc] [rSEt] configuration function.

To reset the grand total to zero from the display mode press the [E] + [▲] buttons for ten seconds until [Lr] [no] is displayed, using the [▼] or [▲] button change the display to [Lr] [YEt] and press [E].

- [▼] + [▲]** Resets the Timer to zero or to the set time 5Et t depending on whether the Timer is configured to *time-up* or *time-down* when the two buttons are operated simultaneously for more than three seconds. This is a configurable function.
- [P] + [▲]** When enabled in the configuration menu, operating these two buttons simultaneously provides direct access to the set time 5Et t and allows adjustment when the timer is in the display mode.
- [P] + [▼]** Shows in succession, firmware version number, instrument function [LRP5E] and any output accessories that are fitted:
 - R Dual Control Outputs

See full instruction manual for description of use when configured as a Clock

