

The **BA378E** is a two input intrinsically safe instrument that may be configured as a Timer or as a Clock. As a Timer it is able to measure and display the elapsed time between external events, or control external events via the status and optional control outputs. When configured as a Clock the instrument can display time in a variety of formats. The BA378E is controlled by two inputs which may be independently configured on-site to operate with a magnetic pick-off, switch contact, proximity detector, open collector or a voltage output sensor. International intrinsic safety certification permits worldwide installation, and a slide-in scale card simplifies identification.

**Configuration** may be performed on-site via the front panel push buttons using the easy to use and well documented menus. The Timer employs a *state* and *event* structure to simplify configuration. The BA378E can be supplied configured to customers requirements including a customer defined printed scalecard for no additional charge.

**Applications as a Timer** include simply displaying the time interval between two events detected by one or two hazardous area sensors such as 2-wire proximity detectors. The Timer can control an external event using the isolated open collector status output if only a single output is required. If it is required to switch more than one circuit, additional dual isolated control outputs are available as a factory fitted option. The Timer is able to perform common industrial timing application such as those associated with dosing or sampling where an intrinsically safe solenoid valve is required to be opened for a defined time. The Timer includes a powerful cycle function which can be configured to repeat the timing function up to 99 times or continuously, with up to 100 hours delay between timed periods.

**As a Clock** local time can be displayed in various twelve or twenty four hour formats and the display may be synchronised to a pre-set time via the external reset input.

Optional control outputs may be configured to switch loads *on* or *off* at pre-set times twice during each twenty four hour period.

**The display** has high contrast and a wide viewing angle, enabling the instrument to be read in most lighting conditions over a wide temperature range.

**IP66 front panel protection** with a neoprene gasket to seal the joint between the instrument and the instrument panel allows the BA378E to be installed in areas that will be washed down.

**International intrinsic safety certification** permits the BA378E to be installed worldwide. When configured to operate with a sensors having a voltage or magnetic pick-up output, the input terminals comply with the requirements for *simple apparatus* reducing system design and documentation.

**Display backlighting** which is internally powered, is available as a factory fitted option. It provides green background illumination enhancing daylight viewing and allowing the display to be easily read at night or when installed in a poorly illuminated area.

**Optional control outputs** can switch hazardous area loads such as a sounder or solenoid valve, or safe area loads via a Zener barrier or isolator. The two galvanically isolated, solid state voltage free outputs may be independently conditioned with normally open or closed outputs. Annunciators on the BA378E display show the status of both control outputs.

**When panel space is limited** the intrinsically safe BA377E single input Timer or Clock provide similar features in a smaller 94 x 48mm enclosure. The BA377E-SS is identical to the BA377E except that it is housed in a rugged stainless steel enclosure with a 10mm thick window that may be installed in an Ex e, Ex p or Ex t panel enclosure without invalidating the enclosure's certification.

# BA378E

## Two input timer or clock

*Intrinsically safe for use in all gas hazardous areas*

- ◆ **Configurable inputs:** magnetic pick-off, switch contact, proximity detector, open collector or voltage pulse.
- ◆ **Separate displays**
- ◆ **Intrinsically safe**
- ◆ **144 x 72mm DIN enclosure with IP66 front protection.**
- ◆ **Isolated status output**
- ◆ **Optional:**  
Backlight  
Dual controls outputs
- ◆ **3 year guarantee**

[www.beka.co.uk/ba378e](http://www.beka.co.uk/ba378e)



# BEKA associates

BEKA associates Ltd. Old Charlton Rd.  
Hitchin, Hertfordshire, SG5 2DA, U.K.  
Tel. (01462) 438301 e-mail [sales@beka.co.uk](mailto:sales@beka.co.uk)  
website: [www.beka.co.uk](http://www.beka.co.uk)

## SPECIFICATION

<b>Power supply</b>			
Voltage	10 to 28V from a Zener barrier or galvanic isolator.		
Current	22mA max plus 16mA for the optional backlight.		
<b>Input A &amp; b</b>			
Switch contact	<b>Lower</b>	<b>Upper</b> switching thresholds	
Proximity detector (NAMUR)	100Ω	1kΩ	
Open collector	1.2mA	2.1mA	
Magnetic pick-off	2kΩ	10kΩ	
Voltage pulse (low)	0	+40mV	
Voltage pulse (high)	1V	3V	28V max
	3V	10V	28V max
<b>Display</b>			
Type	Liquid crystal		
Primary	18mm high		
Secondary	12mm high		
Format	hh:mm:ss ; hh:mm ; mm:ss or s		
<b>Remote Timer reset &amp; Clock sync.</b>			
	Contact closure with resistance less than 10kΩ.		
<b>Timer</b>			
Status output	Isolated, voltage free, open collector, certified as a separate intrinsically safe complying with the requirements for <i>simple apparatus</i> .		
Ron	51Ω + 3V max		
Roff	1MΩ min		
I max	10mA		
Maximum duration	99h 59m and 59s or equivalent in any display format.		
Maximum delay between cycles.	99h 59m and 59s or equivalent in any display format.		
Grand total run-time	5x10 <sup>6</sup> hours maximum		
<b>Clock</b>			
Timekeeping accuracy	Less than ±0.43s error per day over operating temperature range.		
<b>Intrinsic safety</b>			
<b>Europe ATEX and UK UKCA</b>			
Code	Group II Category 1G Ex ia IIC T5 Ga		
Cert. No.s	-40°C ≤ Ta ≤ 70°C <a href="#">ITS16ATEX28408X</a> & <a href="#">ITS21UKEX0098X</a>		
<b>International IECEx</b>			
Code	Ex ia IIC T5 Ga		
Cert. No.	-40°C ≤ Ta ≤ 70°C <a href="#">IECEx ITS 16.0004X</a>		
<b>ETL &amp; cETL</b>			
Code	Class I Div 1 Gp A, B, C, D T5 (USA & Canada) Class II Div 1 Gp E, F, G. Class III Div 1 (USA & Canada) Class I Zone 0 AEx ia IIC T5 Ga (USA) Ex ia IIC T5 Ga (Canada) -40°C ≤ Ta ≤ 70°C		
ETL Control No.	<a href="#">4008610</a>		
<b>China CCC</b>			
	As IECEx - <a href="#">see certificate</a>		
<b>India CCOE/PESO</b>			
	As ATEX - <a href="#">see certificate</a>		
<b>Nonincendive USA &amp; Canada</b>			
Code	ETL & cETL Class I Div 2 Gp A, B, C, D T5 Class II Div 2 Gp F, G. Class III Div 2 -40°C ≤ Ta ≤ 70°C		
ETL Control No.	<a href="#">4008610</a>		
<b>Environmental</b>			
Operating temp	-40 to +70°C display -20 to +70°C		
Storage temp	-40 to +85°C		
Humidity	to 95% at 40°C non condensing		
Vibration	Report available		
Enclosure EMC	Noryl SE1GFN3. Front IP66, rear IP20 Complies with EU and UK Directives		
<b>Mechanical</b>			
Terminals	Screw clamp for 0.5 to 1.5mm <sup>2</sup> cable, removable terminal blocks.		
Weight	0.35kg		
<b>Accessories</b>			
Backlight	Green LED internally powered		
Control outputs	Two outputs each of which may be independently configured as a NO or NC output.		

## DIMENSIONS (mm)

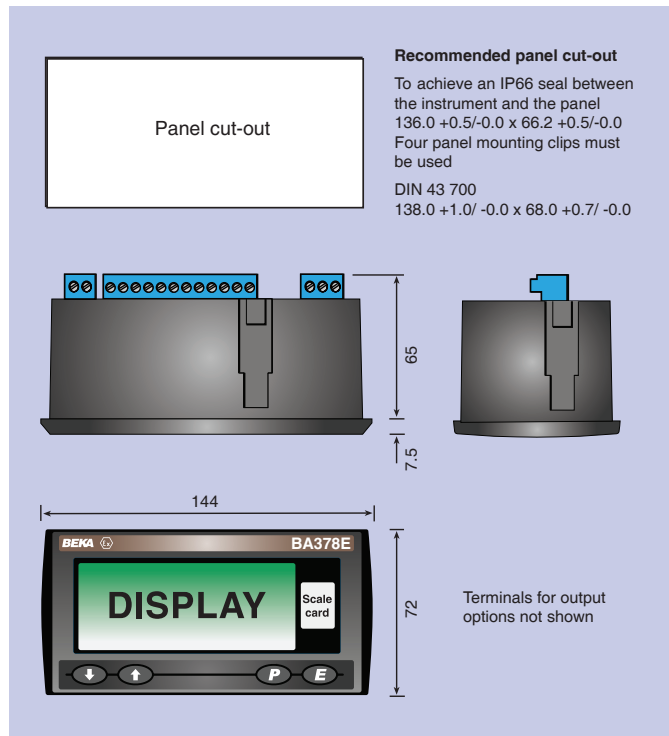

## TERMINAL CONNECTIONS

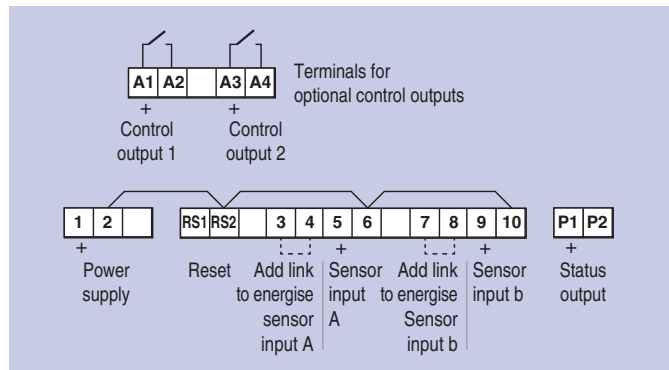

Outputs	Isolated single pole, voltage free solid state switch.
Ron	5Ω + 0.7V max
Roff	1MΩ min
Scale card	Blank card fitted to all instruments. Can be supplied typeset with specified units of measurement for no additional charge at time of purchase. ~
Tag legend	Specified tag number or application printed onto rear of instrument. ~
~ See accessory datasheet for details	

## HOW TO ORDER

Model number	<b>Please specify</b> BA378E
Function	Timer or Clock
Input	Type for each input *
Accessories	Please specify if required
Display backlight	Backlight
Control outputs	Control outputs
Scale card	Legend required
Tag	Legend required

\* BA378E can be supplied configured as required for no additional charge, see instruction manual, which can be downloaded from [www.beka.co.uk/ba378e](http://www.beka.co.uk/ba378e) for details. If configuration information is not supplied, instrument will be configured as a Timer with an open collector input. Can easily be reconfigured on-site.