

## 1. DESCRIPTION

The BA507E, BA508E, BA527E and BA528E are panel mounting, general purpose digital indicators that display the current flowing in a 4/20mA loop in engineering units. They are loop powered but only introduce a 1.2V drop.

The four models are electrically similar, but have different size displays and enclosures.

Model	Display	Bezel size
BA507E	4 digits 15mm high	96 x 48mm
BA527E	5 digits 11mm high and bargraph.	96 x 48mm
BA508E	4 digits 34mm high	144 x 72mm
BA528E	5 digits 29mm high and bargraph.	144 x 72mm

This abbreviated instruction sheet is intended to assist with installation and commissioning, a comprehensive instruction manual describing system design and calibration is available from the BEKA sales office or may be downloaded from the BEKA website.

## Cut-out dimensions

Recommended for all installations. Mandatory to achieve an IP66 seal between the instrument & the panel

**BA507E & BA527E**  
90 +0.5/-0.0 x 43.5 +0.5/-0.0

**BA508E & BA528E**  
136 +0.5/-0.0 x 66.2 +0.5/-0.0

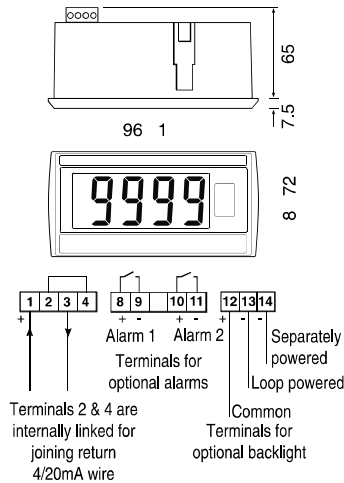
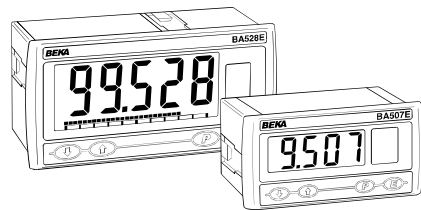

Fig 1 cut out dimensions & terminals

**Abbreviated Instruction for  
BA507E, BA527E, BA508E & BA528E  
general purpose, panel mounting loop  
powered indicators**



## 2. INSTALLATION

All the models have IP66 front of panel protection but should be shielded from direct sunlight and severe weather conditions. The rear of each indicator has IP20 protection.

Issue 2  
16th November 2011

**BEKA associates Ltd.** Old Charlton Rd, Hitchin, Hertfordshire, SG5 2DA, UK  
Tel: +44(0)1462 438301 Fax: +44(0)1462 453971  
e-mail: [sales@beka.co.uk](mailto:sales@beka.co.uk) web: [www.beka.co.uk](http://www.beka.co.uk)

The BA507E, BA508E, BA527E & BA528E are CE marked to show compliance with the European EMC Directive 2004/108/EC

1. Align foot and body of panel mounting clamp by turning screw anticlockwise

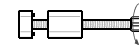

2. Position gasket behind instrument bezel

4. Insert panel clamp into recess and gently pull it onto the dovetail. Engage screw & turn clockwise to tighten the clamp, fit the other clamp(s). Recommended tightening torque 22cNm (1.95lbf.in) Equivalent to finger tight plus one half turn. **DO NOT OVERTIGHTEN**

3. Insert instrument into the panel from the front

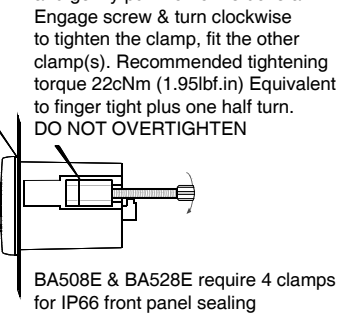

Fig 2 Installation procedure

## EMC

For specified immunity all wiring should be in screened twisted pairs, with the screens earthed at one point

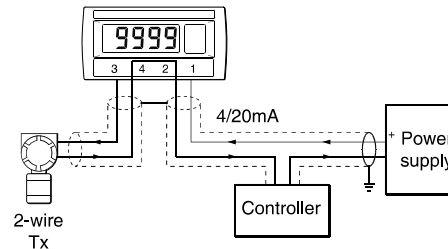

Fig 3 Typical measurement loop

## Scale card

The indicator's units of measurement are shown on a printed scale card visible through a window at the right hand side of the display. The scale card is mounted on a flexible strip that is inserted into a slot at the rear of the instrument as shown below.

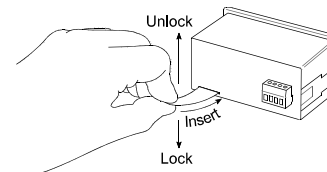

Fig 4 Inserting flexible strip carrying scale card into slot at the rear of indicator.

Thus the scale card can easily be changed without removing the indicator from the panel or opening the instrument enclosure.

New indicators are supplied with a printed scale card showing the requested units of measurement, if this information is not supplied when the indicator is ordered a blank card will be fitted.

A pack of self-adhesive scale cards printed with common units of measurement is available as an accessory from BEKA associates. Custom printed scale cards can also be supplied.

To change a scale card, unclip the protruding end of the flexible strip by gently pushing it upwards and pulling it out of the enclosure. Peel the existing scale card from the flexible strip and replace it with a new printed card, which should be aligned as shown below. Do not fit a new scale card on top of an existing card.

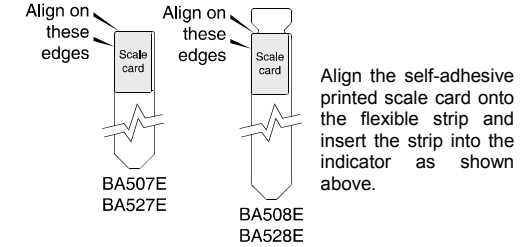

Fig 5 Fitting scale card to flexible strip

## 3. OPERATION

The indicators are controlled via four front panel push buttons. In the display mode i.e. when the indicator is displaying a process variable, these push buttons have the following functions:

**P** While this button is pushed the indicator will display the input current in mA, or as a percentage of the instrument span depending upon how the indicator has been conditioned. When the button is released the normal display in engineering units will return. The function of this push button is modified when optional alarms are fitted to the indicator.

**▼** While this button is pushed the indicator will display the numerical value and analogue bargraph\* the indicator has been calibrated to display with 4mA input. When released the normal display in engineering units will return.

**▲** While this button is pushed the indicator will display the numerical value and analogue bargraph\* the indicator has been calibrated to display with 20mA input. When released the normal display in engineering units will return.

**E** No function in the display mode unless the tare function is being used.

**P + ▼** Indicator displays firmware number followed by version.

**P + ▲** When alarms are fitted provides direct access to the alarm setpoints if the 'ACSP' access setpoints in display mode function has been enabled.

**P + E** Provides access to the configuration menu via optional security code.

\* Only the BA527E & BA528E have a bargraph

#### 4. CONFIGURATION

Indicators are supplied calibrated as requested when ordered, if not specified default configuration will be supplied but can easily be changed on-site.

Fig 4 shows the location of each function within the configuration menu with a brief summary of the function. Please refer to the full instruction manual for detailed configuration information and for a description of the lineariser and the optional dual alarms.

Access to the configuration menu is obtained by pressing the **P** and **E** buttons simultaneously. If the indicator security code is set to the default '0000' the first parameter 'Func' will be displayed. If the indicator is protected by a security code, 'CodE' will be displayed and the code must be entered to obtain access to the menu.

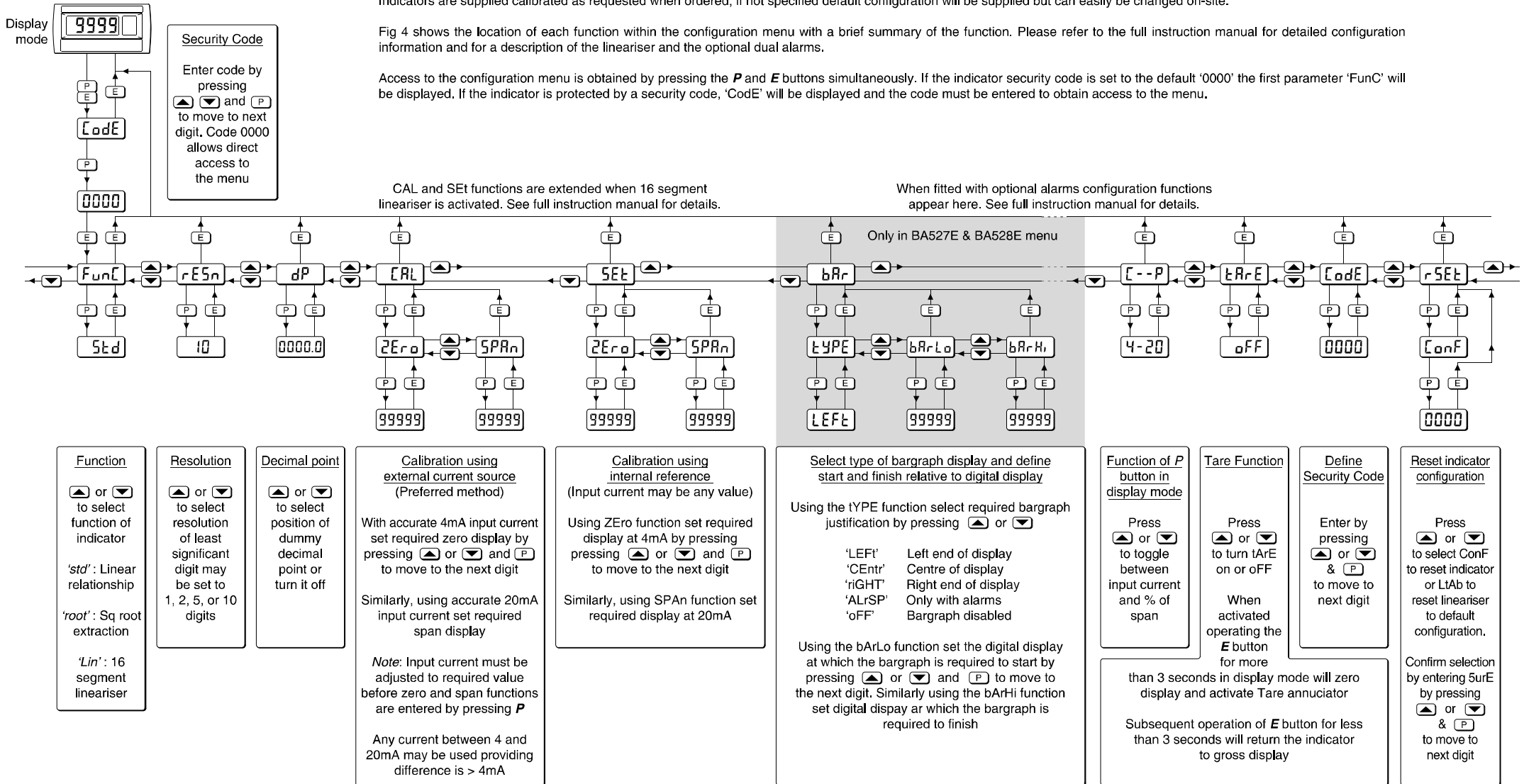

Manuals and datasheets can be downloaded from <http://www.beka.co.uk/lpi5/>

Fig 6 Configuration menu