

# D5231

## I.S. SIL2 Switch/Proximity O.C.-Out Repeater

The Switch/Proximity Detector Repeater D5231 is a module suitable for applications requiring SIL 2 level in safety related systems for high risk industries. The unit can be configured for switches or proximity detectors, located in Hazardous Area, and repeats the input state to a solid-state relay contact in Safe Area. The selectable fault detection circuit is available for proximity sensors or switches equipped with end of line resistors. The module is fully configurable to achieve input/output multiplexing, duplication, inversion, and input logical elaboration (AND, OR). Each output can also be configured to report the cumulative fault of any input subset. Configuration and diagnostic parameters are programmable and can also be monitored/set through Modbus.

### FEATURES

- SIL 2 / SC 3
- Input from Zone 0/Div. 1
- Installation in Zone 2/Div. 2
- Field open and short circuit detection
- Input muxing/duplication/inversion/operations available
- Modbus RTU RS-485 for monitor & configuration
- Fully programmable operating parameters
- Three port isolation, Input/Output/Supply
- High Density, eight channels per unit

### ORDERING INFORMATION

#### Ordering codes

D5231E: 8 channels

#### Accessories

Bus Connector JDFT050, Bus Mounting Kit OPT5096.  
Programmable USB serial line Kit PPC5092 + SWC5090.

### OVERALL DIMENSIONS

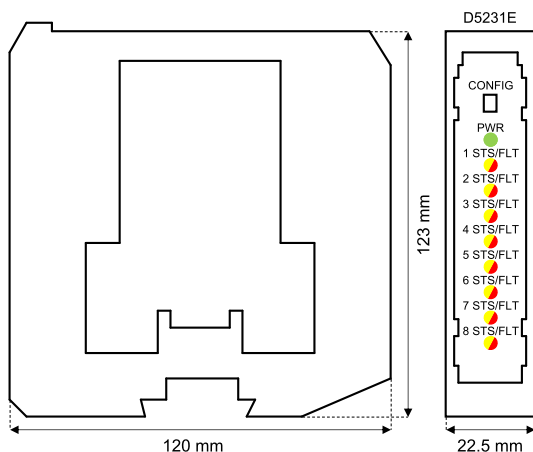

### TECHNICAL DATA

#### Supply

24 Vdc nom (18 to 30 Vdc), reverse polarity protected.

**Current consumption:** 84 mA @ 24 Vdc with short circuit input and output closed, typical.

**Power dissipation:** 2.1 W @ 24 Vdc with short circuit input and output closed, typical.

#### Input

NAMUR standard according to IEC 60947-5-6

**Input switching current levels:** ON  $\geq 2.1$  mA, OFF  $\leq 1.2$  mA.

**Open fault:** current  $\leq 0.05$  mA.

**Short fault:** resistance  $\leq 100 \Omega$ .

**No fault:** current  $\geq 0.35$  mA and resistance  $\geq 360 \Omega$ .

**Input equivalent source:** 8 V 1 k $\Omega$  typical (8 V no load, 8 mA short).

#### Output

Voltage free SPST optocoupled open-collector transistor (solid-state relay, photo-MOS).

**Open-collector/drain rating:** 100 mA @ 35 V ( $\leq 1.0$  V voltage drop).

**Leakage current:**  $\leq 10 \mu\text{A}$  @ 35 V.

**Response time:** 2 ms.

**Frequency response:** 500 Hz maximum.

#### Modbus interface

Modbus RTU RS-485 up to 115.2 kbps for monitor/configuration/control.

#### Isolation

I.S. In/Out 1.5 kV; I.S. In/Supply 1.5 kV; Out/Supply 500 V.

#### Environmental conditions

**Operating temperature:** temperature limits  $-40$  to  $+70$  °C.

**Storage temperature:** temperature limits  $-45$  to  $+80$  °C.

#### Safety description

Associated apparatus and non-sparking electrical equipment.

$U_o = 11.2$  V,  $I_o = 12$  mA,  $P_o = 34$  mW at terminals 21-13, 21-14, 22-15, 22-16, 23-17, 23-18, 24-19, 24-20.

$U_m = 250$  Vrms or Vdc,  $-40$  °C  $\leq T_a \leq 70$  °C.

#### Mounting

DIN-Rail 35 mm, with or without Power Bus or on custom Term. Board.

**Weight:** about 175 g.

**Connection:** by polarized plug-in disconnect screw terminal blocks to accommodate terminations up to 2.5 mm<sup>2</sup> (13 AWG).

**Dimensions:** Width 22.5 mm, Depth 123 mm, Height 120 mm.

# FUNCTION DIAGRAM

Additional installation diagrams may be found in Instruction Manual.

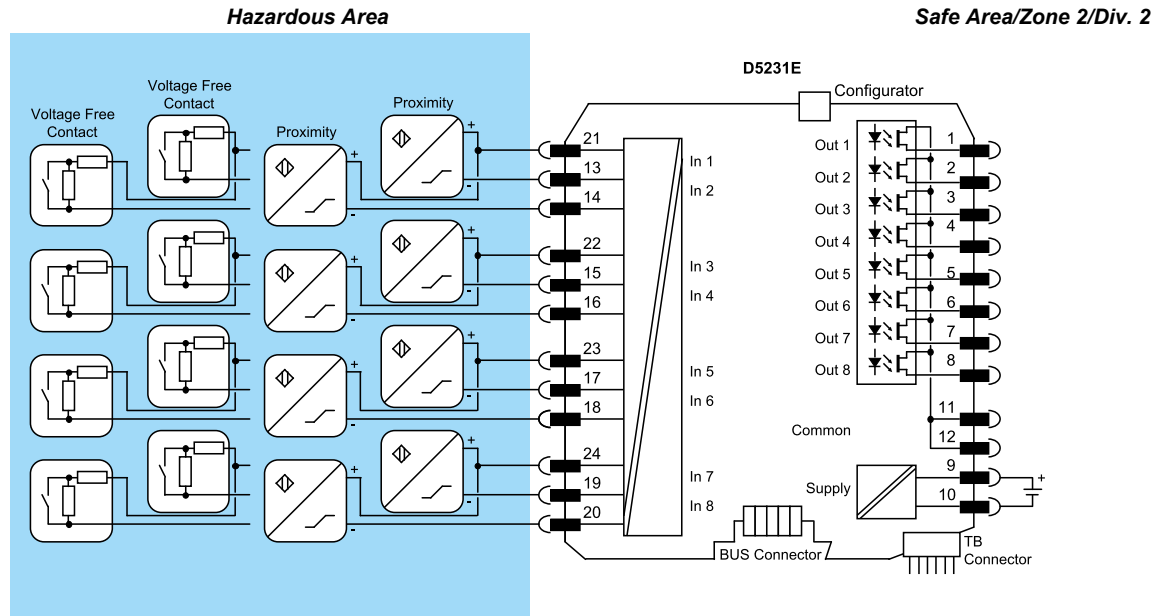

Functional Safety Management Certification: GM International is certified to conform to IEC61508:2010 part 1 clauses 5-6 for safety related systems up to and included SIL3. In addition, GM International products have been granted I.S. certificates from the most credited Notified Bodies in the world.

Data specified in this document are merely descriptive of the products and should be integrated with relevant technical specifications. Our products are in constant development and the information presented herein refers to the time of document issue. No statements concerning a certain condition or suitability for a certain application can be derived from our information. The information given does not release the user from the obligation of own judgment and verification. Terms & Conditions can be found at our website. For more information refer to instruction manual.